



KIRBY® HEAVY DUTY READY CONNECT Evaporators

Legendary toughness
meets revolutionary
performance



Exclusively distributed by

KIRBY
A BEIJER REF Company

KIRBY® HEAVY DUTY READY CONNECT

Evaporators

Introduction and Overview

Legendary Toughness Meets Revolutionary Performance

Revered for its legendary toughness and dependability in critical applications, the Kirby® Heavy Duty evaporator range just got even better with the introduction of the new Ready Connect range.

Kirby® Heavy Duty Ready Connect evaporators are factory fitted with EVD ice, the new control solution for Carel ExV proportional electronic expansion valves directly installed on the evaporator, with a revolutionary design intended specifically for low temperature conditions.

Features & Benefits

Designed specifically for semi-industrial and large commercial applications where optimum cold air flow is paramount, the Kirby® Heavy Duty Ready Connect range offers:

- Simplified installation including factory wiring on all models for fans and heaters
- High airflow from robust fan assemblies ensures efficient pull down and air throw
- Positive electric defrost standard inclusion for all models
- Reversible drain tray
- Simple and fast installation and commissioning
- Extremely short pull-down times
- Precise refrigerant flow
- Enhanced durability rated to IP65
- Operating conditions between -30°C to 40°C



EVD ice is also designed to be compatible with third party regulation and control solutions, using standard communication protocols, or can work as a standalone solution for refrigeration cells and other applications in which compactness and versatility are key.

Kirby® Heavy Duty Ready Connect delivers all the performance benefits available without the need for cabling, welding, or complex configuration. The range also offers the quality and reliability of a factory tested and installed solution, backed by the combined knowledge and strength of both Kirby® and Carel.

Kirby® Heavy Duty Ready Connect – Nomenclature

KHD	C	E	103
			Model Reference
			103
			Grooved Tube
			E Enhanced
			Usage Application
			C Medium Temperature
			F Low Temperature
			Manufacturer Brand
			KHD Kirby Heavy Duty

KP	609	-1
		Kit Number
		-1 E2V30FSMC1
		-2 E2V35FSMC1
		-3 E3V45BSMC1
		-4 E3V55BWRC1
		-5 E3V65BWRC1
		Kit Model
		Carel EXV & EVD ICE
		Manufacturer Brand
		KP Kirby Factory Fitted Kit

HEAVY DUTY READY CONNECT EVAPORATORS

Medium Temperature Performance Data

MODEL	CAPACITY @ 6 KTD (WATTS)	FAN MOTOR DATA						DEFROST HEATER DATA				EXPANSION VALVE DATA	
		240V / 50HZ / 1 PHASE						VOLTS	TOTAL WATTS	TOTAL AMPS	PHASE	FACTORY FITTED KIT	CAREL E2V MODEL
	R134a	NUMBER OF FANS	AIR MOVEMENT		MOTORS (TOTAL)		SOUND POWER dB(A)						
			FLOW (l/s)	THROW (m)	WATTS	AMPS							
KHDCE103	9,482	1	1,920	20	600	1.15	66	415	5,250	8.5	THREE PHASE	KP609-1	E2V30FSMC1
KHDCE136	12,627	2	3,960	22	1,200	2.30	69	415	8,700	14.6	THREE PHASE	KP609-2	E2V35FSMC1
KHDCE161	15,030	2	3,920	22	1,200	2.30	69	415	8,700	14.6	THREE PHASE	KP609-2	E2V35FSMC1
KHDCE188	17,502	2	3,880	22	1,200	2.30	69	415	8,700	14.6	THREE PHASE	KP609-2	E2V35FSMC1
KHDCE214	19,944	2	3,840	22	1,200	2.30	69	415	8,700	14.6	THREE PHASE	KP609-3	E3V45BSMC1
KHDCE263	25,769	3	5,820	24	1,800	3.45	71	415	13,600	23.3	THREE PHASE	KP609-3	E3V45BSMC1
KHDCE316	28,867	3	5,770	24	1,800	3.45	71	415	13,600	23.3	THREE PHASE	KP609-4	E3V55BWRC1
KHDCE366	34,005	4	7,770	25	2,400	4.60	72	415	15,320	28.2	THREE PHASE	KP609-4	E3V55BWRC1
KHDCE430	37,794	4	7,690	25	2,400	4.60	72	415	15,320	28.2	THREE PHASE	KP609-4	E3V55BWRC1
KHDCE538	46,862	5	9,610	26	3,000	5.75	73	415	18,280	33.6	THREE PHASE	KP609-5	E3V65BWRC1

MODEL	CAPACITY @ 6 KTD (WATTS)	FAN MOTOR DATA						DEFROST HEATER DATA				EXPANSION VALVE DATA	
		240V / 50HZ / 1 PHASE						VOLTS	TOTAL WATTS	TOTAL AMPS	PHASE	FACTORY FITTED KIT	CAREL E2V MODEL
	R404A	NUMBER OF FANS	AIR MOVEMENT		MOTORS (TOTAL)		SOUND POWER dB(A)						
			FLOW (l/s)	THROW (m)	WATTS	AMPS							
KHDCE103	11,210	1	1,920	20	600	1.15	66	415	5,250	8.5	THREE PHASE	KP609-2	E2V35FSMC1
KHDCE136	14,080	2	3,960	22	1,200	2.30	69	415	8,700	14.6	THREE PHASE	KP609-2	E2V35FSMC1
KHDCE161	17,270	2	3,920	22	1,200	2.30	69	415	8,700	14.6	THREE PHASE	KP609-2	E2V35FSMC1
KHDCE188	20,100	2	3,880	22	1,200	2.30	69	415	8,700	14.6	THREE PHASE	KP609-3	E3V45BSMC1
KHDCE214	23,040	2	3,840	22	1,200	2.30	69	415	8,700	14.6	THREE PHASE	KP609-3	E3V45BSMC1
KHDCE263	29,860	3	5,820	24	1,800	3.45	71	415	13,600	23.3	THREE PHASE	KP609-5	E3V65BWRC1
KHDCE316	34,280	3	5,770	24	1,800	3.45	71	415	13,600	23.3	THREE PHASE	KP609-5	E3V65BWRC1
KHDCE366	38,900	4	7,770	25	2,400	4.60	72	415	15,320	28.2	THREE PHASE	KP609-5	E3V65BWRC1
KHDCE430	43,780	4	7,690	25	2,400	4.60	72	415	15,320	28.2	THREE PHASE	KP609-5	E3V65BWRC1
KHDCE538	53,980	5	9,610	26	3,000	5.75	73	415	18,280	33.6	THREE PHASE	KP609-5	E3V65BWRC1

HEAVY DUTY READY CONNECT EVAPORATORS

Low Temperature Performance Data

MODEL	CAPACITY @ 6 KTD (WATTS)	FAN MOTOR DATA						DEFROST HEATER DATA				EXPANSION VALVE DATA	
		240V / 50HZ / 1 PHASE						VOLTS	TOTAL WATTS	TOTAL AMPS	PHASE	FACTORY FITTED KIT	CAREL E2V MODEL
	R404A	NUMBER OF FANS	AIR MOVEMENT		MOTORS (TOTAL)		SOUND POWER dB(A)						
			FLOW (l/s)	THROW (m)	WATTS	AMPS							
KHDFE086	9,160	1	1,920	18	600	1.15	66	415	5,250	8.5	THREE PHASE	KP609-2	E2V35FSMC1
KHDFE088	9,990	2	3,960	20	1,200	2.30	69	415	8,700	14.6	THREE PHASE	KP609-2	E2V35FSMC1
KHDFE117	13,330	2	3,920	20	1,200	2.30	69	415	8,700	14.6	THREE PHASE	KP609-2	E2V35FSMC1
KHDFE151	16,100	2	3,880	20	1,200	2.30	69	415	8,700	14.6	THREE PHASE	KP609-3	E3V45BSMC1
KHDFE173	18,340	2	3,840	20	1,200	2.30	69	415	8,700	14.6	THREE PHASE	KP609-3	E3V45BSMC1
KHDFE212	23,430	3	5,820	22	1,800	3.45	71	415	13,600	23.3	THREE PHASE	KP609-5	E3V65BWRC1
KHDFE252	26,760	3	5,770	22	1,800	3.45	71	415	13,600	23.3	THREE PHASE	KP609-5	E3V65BWRC1
KHDFE286	29,400	4	7,770	23	2,400	4.60	72	415	15,320	28.2	THREE PHASE	KP609-5	E3V65BWRC1
KHDFE320	33,830	4	7,690	23	2,400	4.60	72	415	15,320	28.2	THREE PHASE	KP609-5	E3V65BWRC1
KHDFE380	38,530	5	9,610	24	3,000	5.75	73	415	18,280	33.6	THREE PHASE	KP609-5	E3V65BWRC1

HEAVY DUTY READY CONNECT EVAPORATORS

Physical Data

MODEL	DIMENSIONS (mm)											WEIGHT (kg)
	OVERALL LENGTH	B	C	D	E	F	G	H	K	L	M	NET
KIRBY HEAVY DUTY READY CONNECT – MEDIUM TEMPERATURE												
KHDCE103	1,265	890	980	–	–	–	600	685	–	–	905	90
KHDCE136	2,215	890	950	980	–	–	600	685	1,930	–	905	130
KHDCE161	2,215	890	950	980	–	–	600	685	1,930	–	905	140
KHDCE188	2,215	890	950	980	–	–	600	685	1,930	–	905	155
KHDCE214	2,215	890	950	980	–	–	600	685	1,930	–	905	165
KHDCE263	3,165	890	950	950	980	–	600	685	950	1,930	905	215
KHDCE316	3,165	890	950	950	980	–	600	685	950	1,930	905	240
KHDCE366	3,315	1,015	750	750	750	780	715	800	1,500	1,530	1,035	285
KHDCE430	3,315	1,015	750	750	750	780	715	800	1,500	1,530	1,035	305
KHDCE538	4,065	1,015	750	750	750	780	715	800	1,500	2,280	1,035	370
KIRBY HEAVY DUTY READY CONNECT – LOW TEMPERATURE												
KHDFE086	1,265	890	980	–	–	–	600	685	–	–	905	90
KHDFE088	2,215	890	950	980	–	–	600	685	1,930	–	905	130
KHDFE117	2,215	890	950	980	–	–	600	685	1,930	–	905	140
KHDFE151	2,215	890	950	980	–	–	600	685	1,930	–	905	155
KHDFE173	2,215	890	950	980	–	–	600	685	1,930	–	905	165
KHDFE212	3,165	890	950	950	980	–	600	685	950	1,930	905	215
KHDFE252	3,165	890	950	950	980	–	600	685	950	1,930	905	240
KHDFE286	3,315	1,015	750	750	750	780	715	800	1,500	1,530	1,035	285
KHDFE320	3,315	1,015	750	750	750	780	715	800	1,500	1,530	1,035	305
KHDFE380	4,065	1,015	750	750	750	780	715	800	1,500	2,280	1,035	370

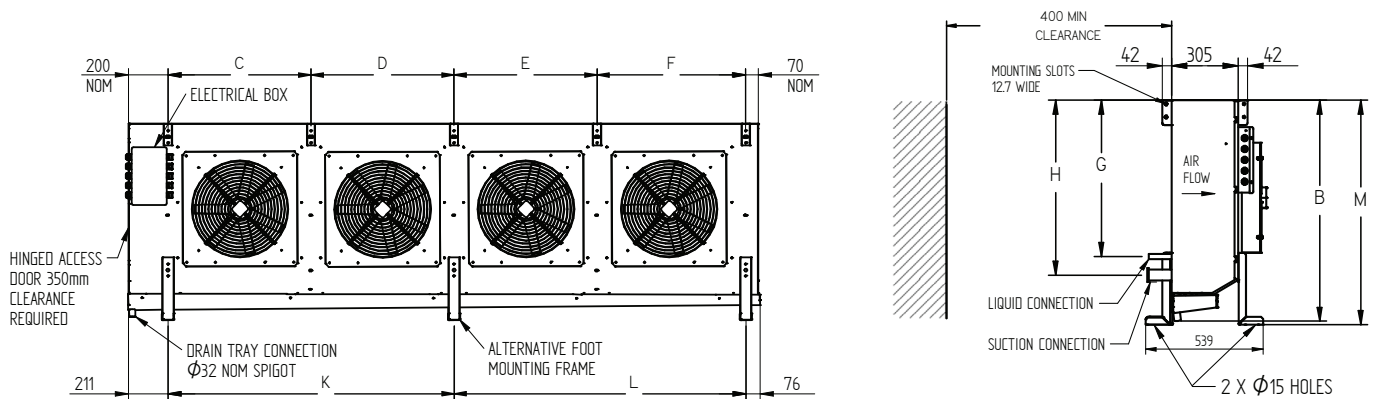

13 23 50
kirbyhvacr.com.au

Exclusively distributed by

KIRBY
A BEIJER REF Company

The contents of this brochure are copyright protected and may not be reproduced in any form without the written consent of Kirby HVAC&R Pty Ltd (T/A Kirby). Recommendations and advice regarding the use of the products described in this publication are to be taken as a guide only and are given without liability on the part of the company or its employees. As Kirby continually improves its product range and processes, Kirby reserves the right to change product specifications without any prior notification. Please refer to the kirbyhvacr.com.au website for the latest version of this publication. The purchaser should independently determine the suitability of the product for the intended use and application and that the product complies with relevant standards. Kirby accepts no responsibility for loss or damage (direct or indirect and including consequential loss, loss of profits or opportunity and economic loss) however arising which results from any errors or omissions in the information contained in this publication or arising from the use or application of the information contained herein.

© Copyright 2022 Kirby HVAC&R Pty Ltd
Kirby HVAC&R Pty Ltd continually strives to improve products and processes. We reserve the right to modify product features without notice. Information is correct at time of printing.